

## 7.5 Volumes of Composite Solids

**Essential Question** How can you estimate the volume of a composite solid?

### 1 ACTIVITY: Estimating Volume

Work with a partner. You work for a toy company and need to estimate the volume of a Minifigure that will be molded out of plastic.

- Estimate the number of cubic inches of plastic that is needed to mold the Minifigure's head. Show your work.
- Estimate the number of cubic inches of plastic that is needed to mold one of the Minifigure's legs. Show your work.

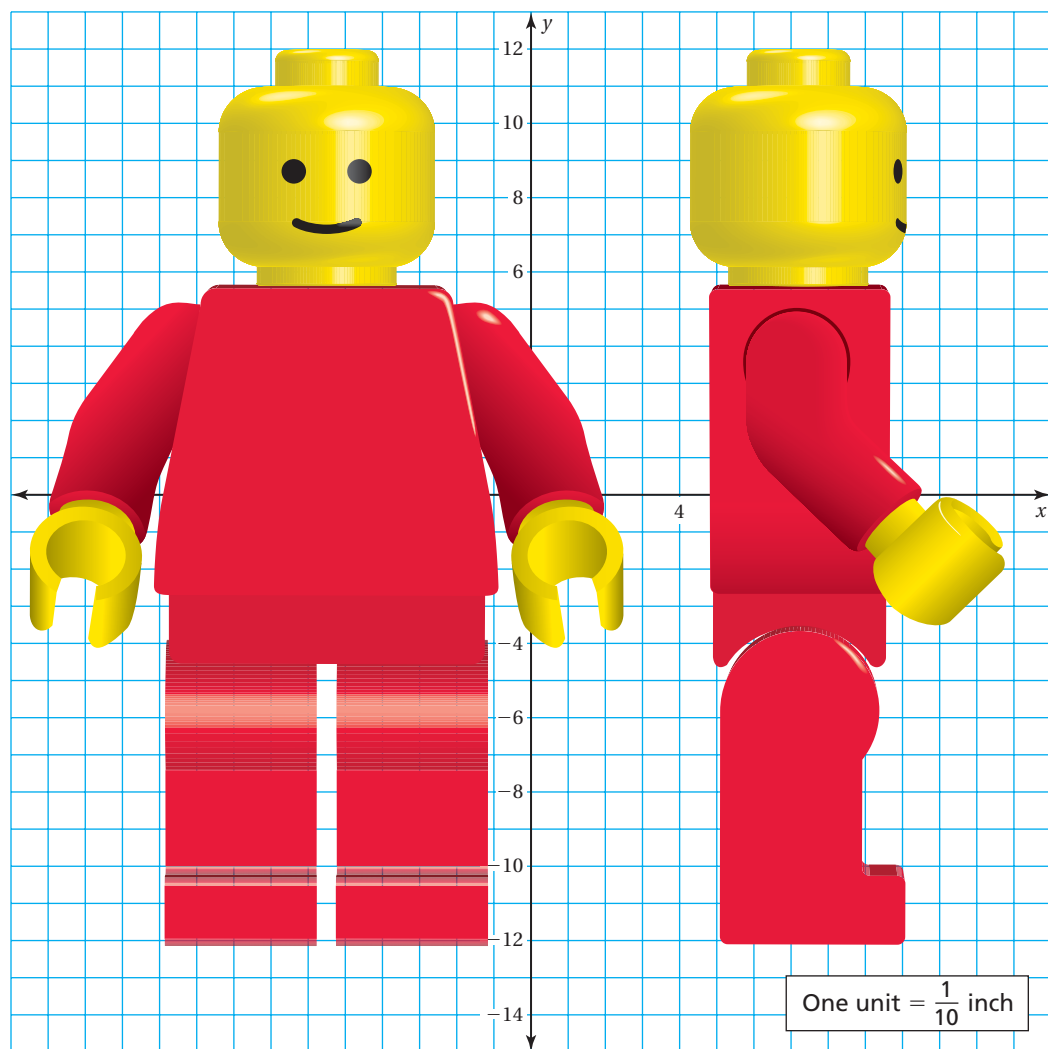

## 2 ACTIVITY: Finding the Volumes of Composite Solids

Work with a partner.

- a. Make a plan for estimating the amount of plastic it takes to make a standard eight-stud LEGO® Brick.

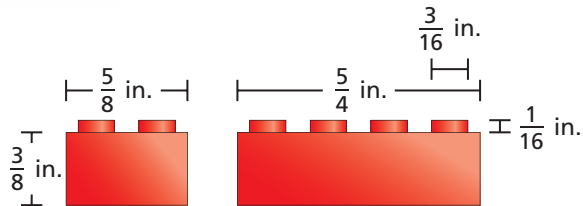

- b. How much water, in cubic inches, would it take to make ten LEGO® Brick ice cubes?

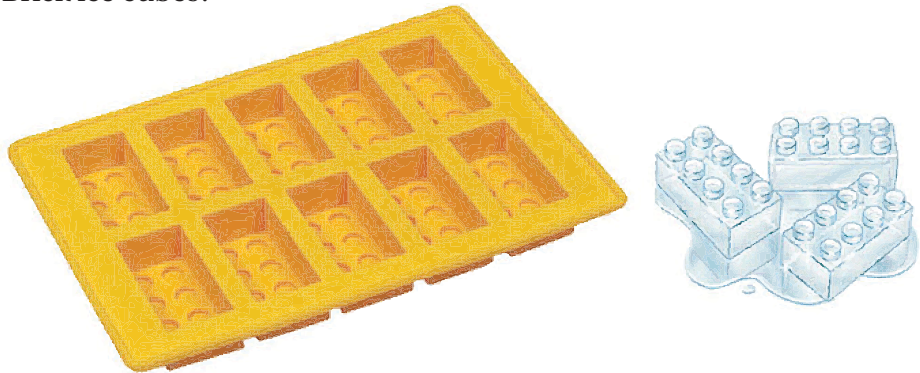

### What Is Your Answer?

3. **IN YOUR OWN WORDS** How can you estimate the volume of a composite solid? Try thinking of some alternative strategies.

#### Practice

Use what you learned about the volumes of composite solids to complete Exercises 4–6 on page 328.

LEGO® and the LEGO logo, the brick and knob configuration, and the Minifigure™ are trademarks of the LEGO Group, and are used here with permission. ©2008 The LEGO Group. All rights reserved.

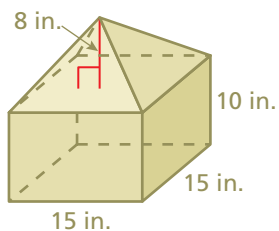
**EXAMPLE 1** Finding the Volume of a Composite Solid

**Find the volume of the composite solid.**

The solid is made up of a square prism and a square pyramid. Find each volume.

*Square prism*

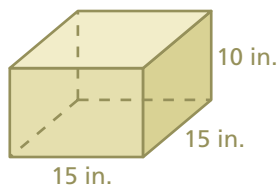

$$\begin{aligned} V &= Bh \\ &= 15(15)(10) \\ &= 2250 \end{aligned}$$

*Square pyramid*

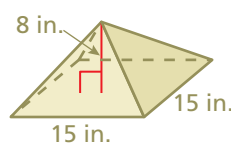

$$\begin{aligned} V &= \frac{1}{3}Bh \\ &= \frac{1}{3}(15)(15)(8) \\ &= 600 \end{aligned}$$

Find the sum:  $2250 + 600 = 2850 \text{ in.}^3$ .

∴ The volume of the composite solid is 2850 cubic inches.

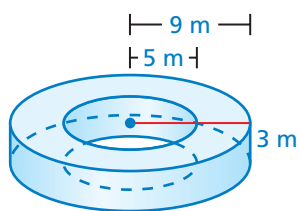
**EXAMPLE 2** Finding the Volume of a Composite Solid

**Find the volume of the composite solid. Round your answer to the nearest tenth.**

The solid is a cylinder with a cylinder-shaped hole. Find each volume.

*Entire Cylinder*

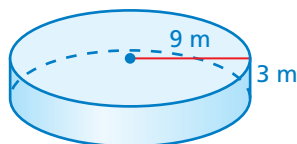

$$\begin{aligned} V &= Bh \\ &= \pi(9)^2(3) \\ &= 243\pi \end{aligned}$$

*Cylinder-Shaped Hole*

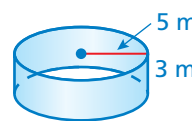

$$\begin{aligned} V &= Bh \\ &= \pi(5)^2(3) \\ &= 75\pi \end{aligned}$$

Find the difference:  $243\pi - 75\pi = 168\pi \approx 527.5 \text{ m}^3$ .

∴ The volume of the composite solid is about 527.5 cubic meters.

### On Your Own

Find the volume of the composite solid. Round your answer to the nearest tenth.

1.

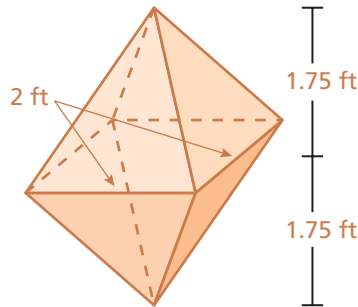

2.

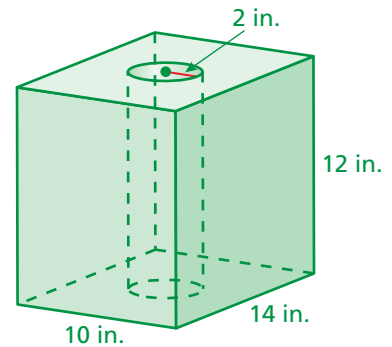

### EXAMPLE 3 Real-Life Application

What is the volume of the silver ring in an Argentine peso? Round your answer to the nearest tenth.

The coin is a cylinder. The silver ring is the portion remaining when the inner cylinder is removed. Find the volume of each cylinder.



*Entire cylinder*



$$\begin{aligned} V &= Bh \\ &= \pi(11.5)^2(2.2) \\ &= 290.95\pi \end{aligned}$$

*Inner cylinder*



$$\begin{aligned} V &= Bh \\ &= \pi(8.5)^2(2.2) \\ &= 158.95\pi \end{aligned}$$

Subtract the volume of the inner cylinder from the volume of the entire cylinder:  $290.95\pi - 158.95\pi = 132\pi \approx 414.5 \text{ mm}^3$ .

∴ The volume of the silver ring is about 414.5 cubic millimeters.

### On Your Own

- WHAT IF?** In Example 3, how would the volume of the silver ring change if the coin were only half as thick?
- Find the volume of the composite solid. Round your answer to the nearest tenth.

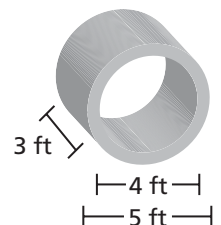

## Vocabulary and Concept Check

- VOCABULARY** What is a composite solid?
- WRITING** Explain how to find the volume of the composite solid.
- CRITICAL THINKING** Explain how finding the volume in Example 2 is different from finding the volume in Example 1.

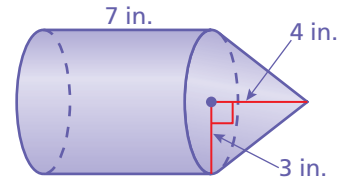

## Practice and Problem Solving

Find the volume of the composite solid. Round your answer to the nearest tenth.

1 2

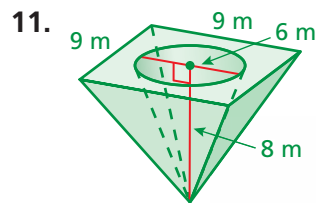
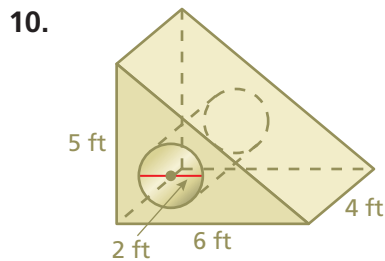
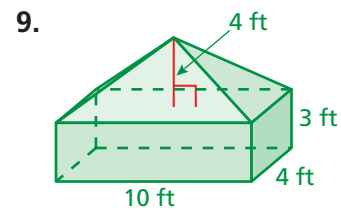
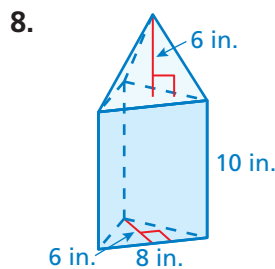
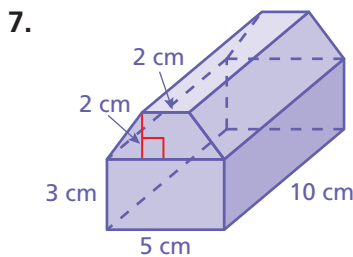
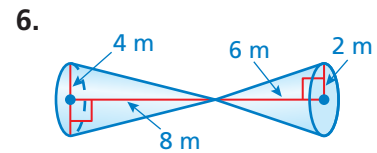
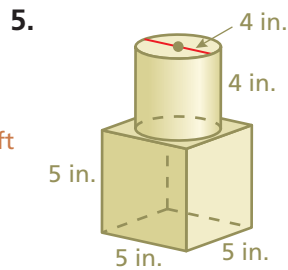
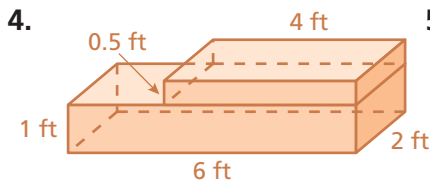

12. **BIRD FEEDER** The cedar waxwing measures about 6 inches from head to tail. The green hexagonal part of the birdfeeder has a base area of 18 square inches. Estimate how much bird seed the bird feeder will hold. Explain how you found your estimate.





13. **CAKE** The raspberry layer cake has a diameter of 10 inches and a height of 5 inches.
- About what percent of the cake is remaining?
  - Estimate the volume of the remaining cake.

14. **KICKBOARD** A foam kickboard used for swimming has two identical hand grips.
- Find the volume of the kickboard.
  - One cubic inch of foam weighs about 0.007 pound. How much does the kickboard weigh?

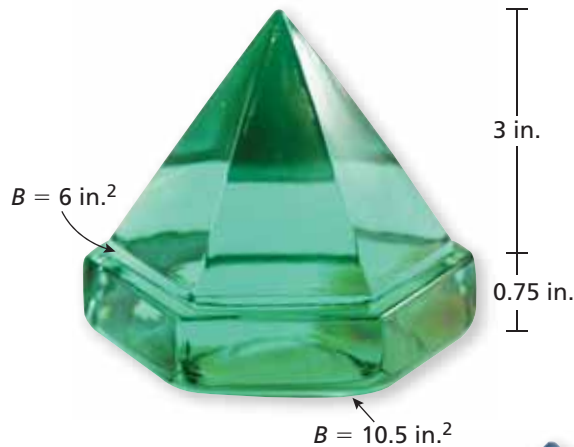
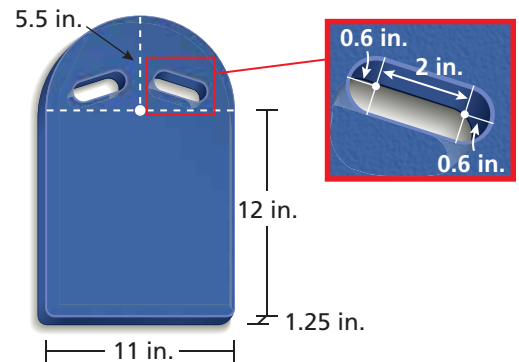

15. **PAPERWEIGHT** Estimate the amount of glass in the paperweight. Explain how you found your estimate.

16. **Puzzle** The volume of each group of solids is given. Find the volume of each of the four types of blocks.



$$V = 8\pi + 8$$



$$V = 8\pi + 28$$

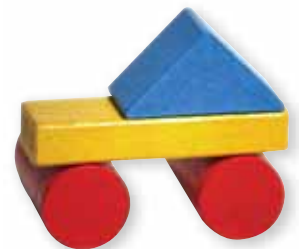

$$V = 8\pi + 20$$



## Fair Game Review

What you learned in previous grades & lessons

The two figures are similar. Find the ratio (red to blue) of the areas.

17.

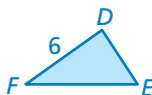
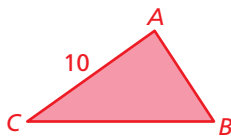

18.

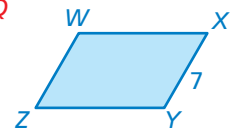
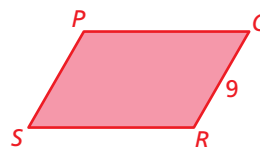

19. **MULTIPLE CHOICE** A fire hydrant releases 1200 gallons of water in 4 minutes. What is the rate of release in gallons per second?

- (A) 3 gal/sec      (B) 5 gal/sec      (C) 30 gal/sec      (D) 300 gal/sec