

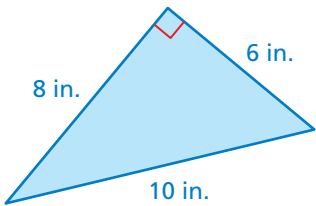
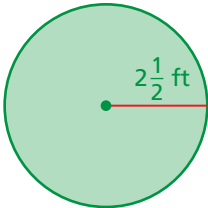
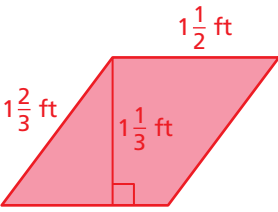

1.5 Converting Units of Measure

Essential Question How can you convert from one measurement system to another?

1 ACTIVITY: Converting Units of Measure

Work with a partner. Copy and complete the table. Describe the pattern in the completed table.

		Perimeter, in. to ft ratio	Area, in. ² to ft ² ratio
Sample: a.		$\frac{60 \text{ in.}}{5 \text{ ft}} = \frac{12 \text{ in.}}{1 \text{ ft}}$	$\frac{216 \text{ in.}^2}{1.5 \text{ ft}^2} = \frac{144 \text{ in.}^2}{1 \text{ ft}^2}$
b.		$\frac{\square \text{ in.}}{\square \text{ ft}} = \square$	$\frac{\square \text{ in.}^2}{\square \text{ ft}^2} = \square$
c.		$\frac{\square \text{ in.}}{\square \text{ ft}} = \square$	$\frac{\square \text{ in.}^2}{\square \text{ ft}^2} = \square$
d.		$\frac{\square \text{ in.}}{\square \text{ ft}} = \square$	$\frac{\square \text{ in.}^2}{\square \text{ ft}^2} = \square$
e.		$\frac{\square \text{ in.}}{\square \text{ ft}} = \square$	$\frac{\square \text{ in.}^2}{\square \text{ ft}^2} = \square$

2 ACTIVITY: Comparing Units of Measure

Work with a partner. Name the units for each pair of “rulers”.

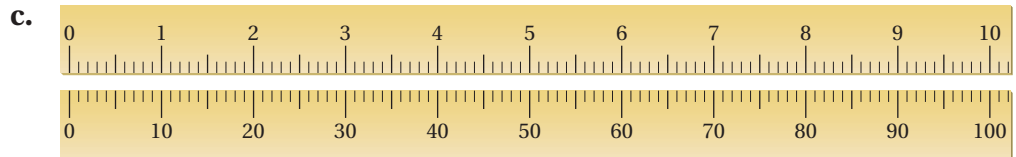
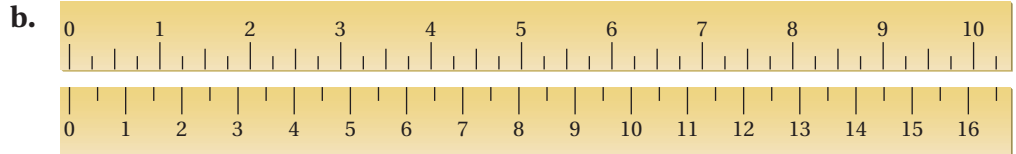
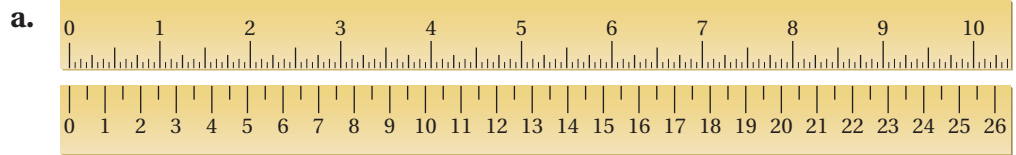

3 ACTIVITY: Puzzle

Who is correct, Fred or Sam? Explain your reasoning.

John said, “We left camp this morning, and walked 1 mile due south. Then, we saw a polar bear and turned due east and ran 1 kilometer. Finally, we turned due north and walked 1 mile and ended back at camp.”

Fred said, “That is not possible!”

Sam explained, “Yes it is. And I know exactly where the camp was.”



What Is Your Answer?

4. **IN YOUR OWN WORDS** How can you convert from one measurement system to another? The examples on these two pages are measurements of length and area. Describe a conversion between two types of temperature units.

Practice

Use what you learned about converting units of measure to complete Exercises 4–6 on page 35.

Key Vocabulary

conversion factor,
p. 32

To convert between customary and metric units, multiply by one or more *conversion factors*.

Key Idea

Conversion Factor

A **conversion factor** is a rate that equals 1.

Relationship

Conversion factors

Example 1 m \approx 3.28 ft

$$\frac{1 \text{ m}}{3.28 \text{ ft}} \text{ and } \frac{3.28 \text{ ft}}{1 \text{ m}}$$

EXAMPLE 1 Converting Between Systems

Convert 20 centimeters to inches.

Method 1: Use a conversion factor.

$$20 \text{ cm} \cdot \frac{1 \text{ in.}}{2.54 \text{ cm}} \approx 7.87 \text{ in.}$$

$$1 \text{ in.} \approx 2.54 \text{ cm}$$

So, 20 centimeters is about 7.87 inches.

Method 2: Use a proportion.

Let x be the number of inches equivalent to 20 centimeters.

$$\frac{\text{inches}}{\text{centimeters}} \rightarrow \frac{1}{2.54} \approx \frac{x}{20} \leftarrow \frac{\text{inches}}{\text{centimeters}}$$

Write a proportion.

$$20 \cdot \frac{1}{2.54} \approx 20 \cdot \frac{x}{20}$$

Multiply each side by 20.

$$7.87 \approx x$$

Simplify.

So, 20 centimeters is about 7.87 inches.

On Your Own

Copy and complete the statement.

1. 10 qt \approx L

2. 4 km \approx mi

3. 18 in. \approx cm

4. 84 lb \approx kg

Now You're Ready
Exercises 7–15

EXAMPLE 2 Converting a Rate: Changing One Unit

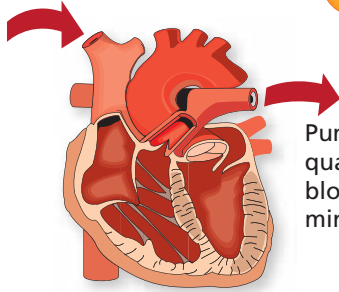

Pumps 5 quarts of blood per minute

Convert the pumping rate of the human heart to liters per minute.

$$\frac{5 \text{ qt}}{1 \text{ min}} \cdot \frac{0.95 \text{ L}}{1 \text{ qt}} \approx \frac{4.75 \text{ L}}{1 \text{ min}}$$

$1 \text{ qt} \approx 0.95 \text{ L}$

••• The rate of 5 quarts per minute is about 4.75 liters per minute.

EXAMPLE 3 Converting a Speed: Changing Both Units

Convert the speed of the zip liner to feet per second.

15 miles per hour

Study Tip

Here is another way to convert the rate in Example 3.

- Write the rate as $15 \frac{\text{miles}}{\text{hour}}$.
- Substitute 5280 feet for miles and 3600 seconds for hour.

$$\begin{aligned} \frac{15 \text{ mi}}{1 \text{ h}} \left(\frac{5280 \text{ ft}}{1 \text{ mi}} \right) \left(\frac{1 \text{ h}}{3600 \text{ sec}} \right) &= \frac{15 \cdot 5280 \text{ ft}}{3600 \text{ sec}} \\ &= \frac{79,200 \text{ ft}}{3600 \text{ sec}} \\ &= \frac{22 \text{ ft}}{1 \text{ sec}} \end{aligned}$$

$1 \text{ mi} = 5280 \text{ ft}$ $1 \text{ h} = 3600 \text{ sec}$

••• The speed of the zip liner is 22 feet per second.



On Your Own

5. An oil tanker is leaking oil at a rate of 300 gallons per minute. Convert this rate to gallons per second.
6. A tennis ball travels at a speed of 120 miles per hour. Convert this rate to feet per second.
7. A kite boarder travels at a speed of 10 meters per second. Convert this rate to kilometers per minute.

Now You're Ready
Exercises 18–23

Key Idea

Converting Units for Area or Volume

To convert units for area, multiply the area by the *square* of the conversion factor.

To convert units for volume, multiply the volume by the *cube* of the conversion factor.

EXAMPLE 4 Converting Units for Area

Remember

Area is measured in *square units*. Volume is measured in *cubic units*.

The painting *Fracture* by Benedict Gibson has an area of 2880 square inches. What is the area of the painting in square feet?

$$\begin{aligned} 2880 \text{ in.}^2 &= 2880 \text{ in.}^2 \cdot \left(\frac{1 \text{ ft}}{12 \text{ in.}}\right)^2 \\ &= 2880 \cancel{\text{ in.}^2} \cdot \frac{1 \text{ ft}^2}{144 \cancel{\text{ in.}^2}} \\ &= \frac{2880}{144} \text{ ft}^2 \\ &= 20 \text{ ft}^2 \end{aligned}$$



∴ The area of the painting is 20 square feet.

EXAMPLE 5 Converting Units for Volume

What is the volume of the cylinder in cubic centimeters?

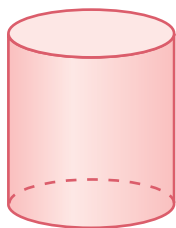

Volume = 80 m^3

$$\begin{aligned} 80 \text{ m}^3 &= 80 \text{ m}^3 \cdot \left(\frac{100 \text{ cm}}{1 \text{ m}}\right)^3 \\ &= 80 \cancel{\text{ m}^3} \cdot \frac{1,000,000 \text{ cm}^3}{1 \cancel{\text{ m}^3}} \\ &= 80,000,000 \text{ cm}^3 \end{aligned}$$

∴ The volume is 80,000,000 cubic centimeters.

On Your Own

Now You're Ready
Exercises 30–35

- The painting *Busy Market* by Haitian painter Frantz Petion has an area of 6 square feet. What is the area of the painting in square inches?
- The volume of a pyramid is 50 cubic centimeters. What is the volume of the pyramid in cubic millimeters?



1.5 Exercises



Vocabulary and Concept Check

- VOCABULARY** Is $\frac{10 \text{ mm}}{1 \text{ cm}}$ a conversion factor? Explain.
- WRITING** Describe how to convert 2 liters per hour to milliliters per second.
- WHICH ONE DOESN'T BELONG?** Which measurement does *not* belong with the other three? Explain your reasoning.

100 in.

254 cm

6.25 ft

2.54 m



Practice and Problem Solving

Find the perimeter in feet and in yards.

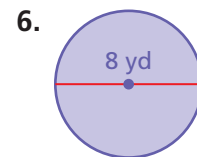
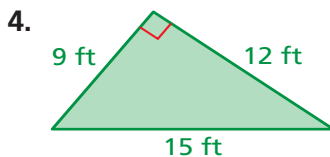

Copy and complete the statement.

1 7. 12 L \approx qt

8. 14 m \approx ft

9. 4 ft \approx m

10. 64 lb \approx kg

11. 0.3 km \approx mi

12. 75 in. \approx cm

13. 17 kg \approx lb

14. 15 cm \approx in.

15. 9 mi \approx km

16. **ERROR ANALYSIS** Describe and correct the error in converting the units.

$$\begin{aligned} 8 \text{ L} &\approx 8 \text{ L} \cdot \frac{0.95 \text{ qt}}{1 \text{ L}} \\ &= 8 \cancel{\text{L}} \cdot \frac{0.95 \text{ qt}}{1 \cancel{\text{L}}} \\ &= 7.6 \text{ qt} \end{aligned}$$

17. **BRIDGE** The Mackinac Bridge, in Michigan, is the third longest suspension bridge in the United States.

- How high above the water is the roadway in meters?
- The bridge has a length of 26,372 feet. What is the length in kilometers?



Copy and complete the statement.

2 3 18. $\frac{13 \text{ km}}{\text{h}} \approx \frac{\square \text{ mi}}{\text{h}}$

19. $\frac{22 \text{ L}}{\text{min}} = \frac{\square \text{ L}}{\text{h}}$

20. $\frac{63 \text{ mi}}{\text{h}} = \frac{\square \text{ mi}}{\text{sec}}$

21. $\frac{3 \text{ km}}{\text{min}} \approx \frac{\square \text{ mi}}{\text{h}}$

22. $\frac{17 \text{ gal}}{\text{h}} \approx \frac{\square \text{ qt}}{\text{min}}$

23. $\frac{6 \text{ cm}}{\text{min}} = \frac{\square \text{ m}}{\text{sec}}$

24. **SNAIL** What is the speed of the snail in kilometers per hour?



0.013 meter per second

25. **BLOOD DRIVE** A donor gives blood at a rate of 0.125 pint per minute. What is the rate in milliliters per second?

26. **POSTER** A poster of your favorite band has a width of 15 inches. You have a space on your wall that has a width of 1.2 feet. Will the poster fit? Explain.



27. **ROME** Ancient Romans used the *talent* and the *mina* as measures of weight. How many minas are in 100 pounds?

28. **FUEL EFFICIENCY** The fuel efficiency standard for cars in Japan is 20 kilometers per liter. The fuel efficiency standard for cars in the United States is 28 miles per gallon. Which country has a greater fuel efficiency standard?

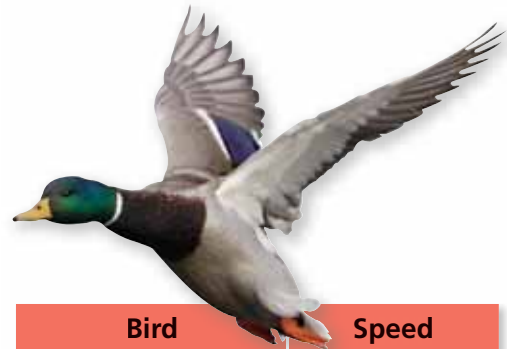

29. **BIRDS** The table shows the flying speeds of several birds.

- Which bird is the fastest? Which is the slowest?
- The peregrine falcon has a dive speed of 322 kilometers per hour. Is the dive speed of the peregrine falcon faster than the flying speed of any of the birds? Explain.

Bird	Speed
Spine-tailed swift	2843.2 m/min
Spur-winged goose	129.1 ft/sec
Elder duck	31.3 m/sec
Mallard	65 mi/h

Copy and complete the statement.

4 30. $4 \text{ yd}^2 = \square \text{ ft}^2$

31. $0.00125 \text{ mi}^2 = \square \text{ ft}^2$

32. $30 \text{ mm}^2 = \square \text{ cm}^2$

5 33. $3 \text{ km}^3 = \square \text{ m}^3$

34. $2 \text{ ft}^3 = \square \text{ in.}^3$

35. $420 \text{ cm}^3 = \square \text{ m}^3$

36. **FIREWOOD** The volume of a cord of firewood is 128 cubic feet. What is the volume of a cord of firewood in cubic yards? Round your answer to the nearest hundredth.

37. **FABRIC COVER** The pattern shows the dimensions of a fabric cover for a tissue box.

- Use the pattern and a ruler to estimate the volume of a tissue box.
- The volume of a tissue is about 0.864 cubic inch. About how many tissues are in a box?

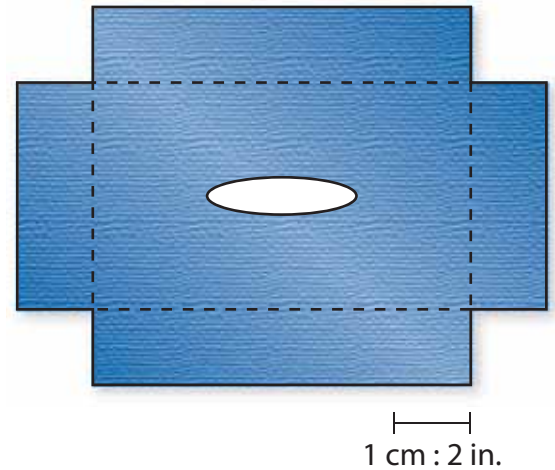

38. **PROJECT** The table shows the currencies of four countries.

- RESEARCH** Use the Internet to find the exchange rates for the currencies listed in the table.
- How much of each currency would you receive in exchange for \$20?

Country	Currency	Value in Dollars
United States	Dollar	\$1
Japan	Yen	
Spain	Euro	
Great Britain	Pound	

39. **SHAMPOO** Your shampoo bottle is 80% full. The total volume of the bottle is 565 cubic centimeters. How much shampoo have you used? Write your answer in cubic millimeters.

40. **Critical Thinking** You make Floating Island Punch for a party.

- Your punch bowl holds 6 liters. Will the punch fit into the bowl? Explain.
- One milliliter is equal to 1 cubic centimeter. Can you store the punch in a container with a capacity of 3000 cubic centimeters?



Recipe for: Floating Island Punch	
From: Mom	
2 cups water	2 cups sugar
1 L ginger ale	1 L carbonated water
1 pt orange sherbet	4 cups ice
$1\frac{1}{2}$ cups frozen lemonade concentrate	$1\frac{1}{2}$ cups frozen orange juice concentrate



Fair Game Review what you learned in previous grades & lessons

Plot the ordered pair in a coordinate plane.

41. (1, 2)

42. (0, -3)

43. (-6, -8)

44. (-5, 7)

45. **MULTIPLE CHOICE** Which equation shows direct variation?

\checkmark

(A) $y = 2x + 1$

(B) $y = \frac{1}{3}x$

(C) $4 = xy$

(D) $y = 2x - 1$